



Compact Security Podium

Economical, Modern Appearance, Light Weight

The smallest security station in our line, the Compact Security Podium, is ideal for any business with limited space. A stylish stainless steel accent gives the podium a contemporary look. Recessed casters, easy grab handles, and its smaller size make the podium easy to transport, and fits in the back seat of most cars.

The optional LED kit is integrated into the podium and includes everything you need to operate:

- 1 translucent white acrylic front panel
- Waterproof LED strips with multiple color options
- Rechargeable sealed Li-polymer battery w/ power supply and remote control. Battery lasts for over 14 hours on a single charge.



Shown above with LED Kit upgrade

Basic Features

- Stylish stainless steel accents
- Easy grab handles for portability
- Folding door and drawer handles
- 2 Heavy-Duty Non-Locking Casters
- 2 cam locks w/ 4 keys
- 18 gauge steel
- Scratch-resistant textured black finish
- Umbrella Holder
- Brushed stainless steel working surface
- Pre-assembled
- Replaceable Parts
- Manufacturer's Warranty

Dimensions: 18"W x 19"D x 48.5"H

Weight: 98 lbs.

Upgrade Options

Door Lock

Combination Lock + \$85.00

Trim Colors

Stainless Steel or Black Trim

Sneeze Guard

3 Panel + \$75.00

Miscellaneous

Cash Tray Drawer Insert + \$65.00

Lock Box + \$60.00

Shelf + \$35.00

Artwork Upgrades

Large Magnet + FROM \$205.00

Vinyl Decal + FROM \$275.00

Accessories

LED Kit + \$400.00

Podium Cover + \$80.00

Heavy-duty Podium Cover + \$115.00

Umbrella + \$255.00



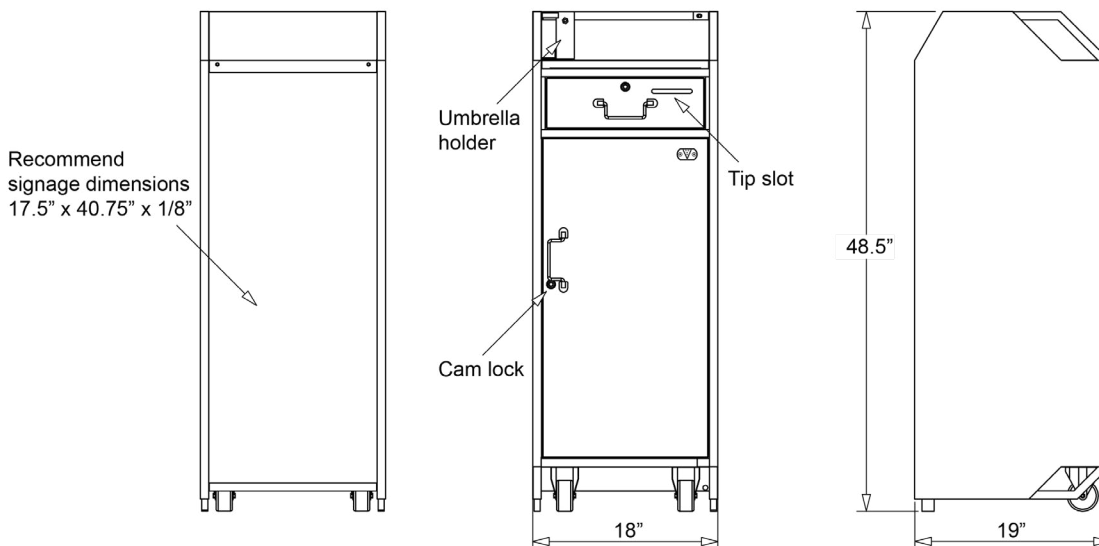

**TOTAL COST
BEFORE DELIVERY**

\$750 (basic options)